

Retaining brake range technical data

Aluminium & stainless steel

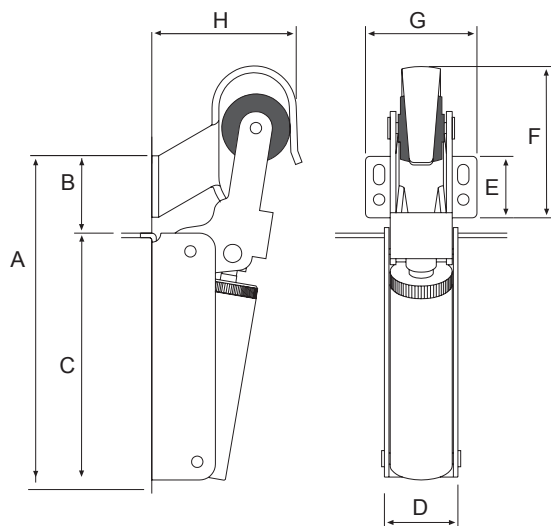

Dimensional information: SS & alum

Mod.	Force (N)	D/Width	D/Kg	A	B	C	D	E	F	G	H
BI0G	30 N	75cm	15	183,5	75	108,5	32	27	65,5	49	64
BI1G	60 N	85cm	40								
BI2G	80 N	110cm	80	200	75	125	36				
BI3G	115 N	125cm	100								

0G & 1G for interior and light doors
 2G for doors with a lot of use
 3G for heavy doors

Measurements Table (in mm)
 D = Door

Retaining brake 0G, 1G, 2G & 3G anti-door slammer Aluminium & stainless steel



The 0G, 1G, 2G and 3G range of retaining brakes are an ideal solution for all door types where the possibility of door slamming exists.

Ideal for low to extreme traffic environments, modest to extreme weather conditions, internal or external doors including light weight to very heavy doors, the 0G, 1G, 2G and 3G range of retaining brakes are easily installed on all existing doors without having to dismantle the door.

Stocked in large quantities, the Justor 0G, 1G, 2G and 3G range retaining brakes have a speed regulator for detailed control of door closure speed; aesthetically pleasing to the eye, cost effective & highly functional, the *only* solution to consider for high wind environments.

All Justor Retaining Brakes are maintenance free - due to their unique construction, they are fully adjustable while the door is still hanging and do not require periodic greasing or recharging. The 0G, 1G, 2G and 3G range of retaining brakes silently engages in the last 10° of door swing closure to prevent slamming. Made in Spain By Justor, the 0G, 1G, 2G or 3G retaining brake is a unique solution for an age old problem of high wind and drafts slamming doors.

Quick facts:

- Eliminates possible door slams
- Hydraulic mechanism
- Silent mechanism
- For light or heavy doors
- Acts on the last 10° of closure
- Variable closing strength
- Detailed instructions included
- Available in silver, bronze & stainless steel
- Quick & simple installation without dismantling of door
- 2 year manufacturer's guarantee



Anatomy of a retaining brake:

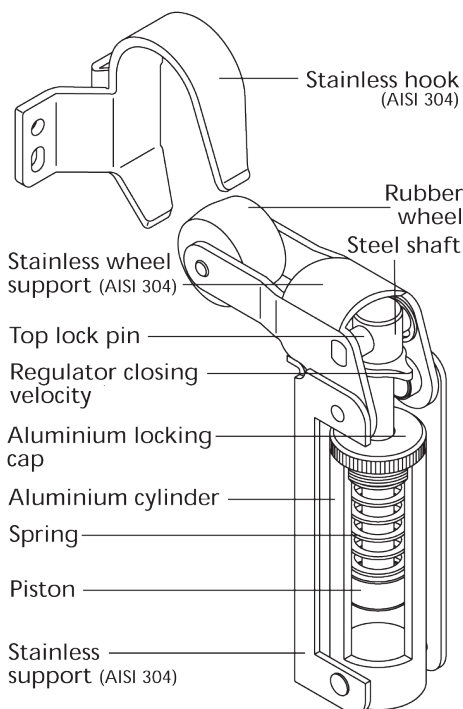

**Ideal for sliding doors and gates.
install it horizontally & add sliding
bracket "XGS1"**

Order codes:

Base material: Aluminium

- B10GS - Silver
- B10GB - Bronze
- B11GS - Silver
- B11GB - Bronze
- B12GS - Silver
- B12GB - Bronze
- B13GS - Silver
- B13GB - Bronze

Base material: Stainless steel 304

- B10GSS - AISI 304 stainless
- B11GSS - AISI 304 stainless
- B12GSS - AISI 304 stainless
- B13GSS - AISI 304 stainless

Sliding door bracket

- XGS1 - Sliding bracket